

— **MÁQUINA DUPLICADORA ECCO PLUS**
Manual de instrucciones

— **KEY CUTTING MACHINE ECCO PLUS**
Instruction manual

— **KOPIERMASCHINE ECCO PLUS**
Anweisungshandbuch

— **MACCHINA DUPLICATRICE ECCO PLUS**
Manuale d'istruzione

— **MACHINE A TAILLER LES CLES ECCO PLUS**
Notice d'utilisation

— **MÁQUINA DUPLICADORA ECCO PLUS**
Manual de instruções

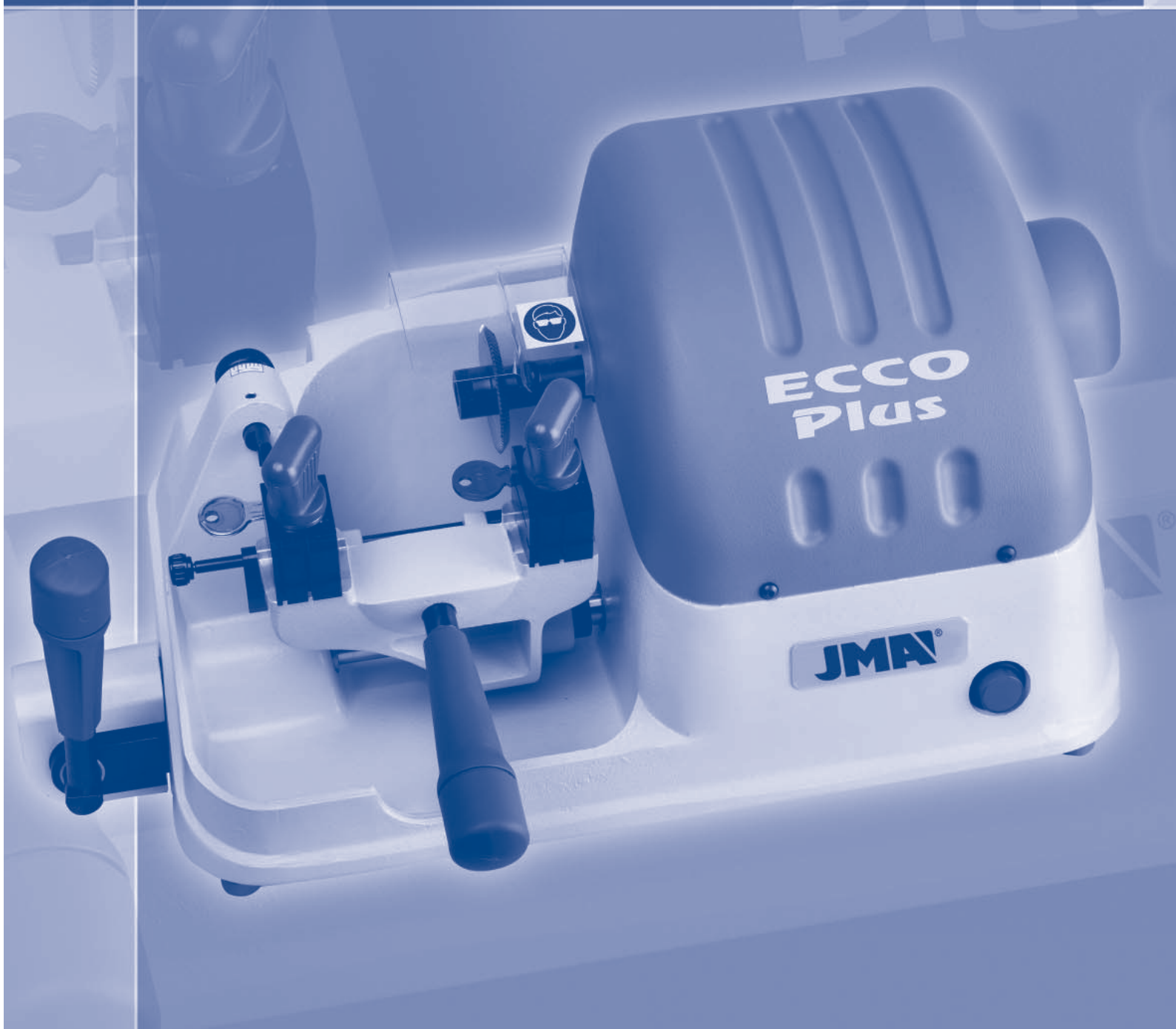

1 Presentation

and general aspects

1.1 General points

The ECCO PLUS key cutting machine has been designed taking into account the safety standards currently in force in the EU.

Although the machine is not difficult to install, it is best not to try to install, adjust or use it without having first read this manual.

The machine leaves our factory ready for use and only requires the carrying out of calibration operations for the tools that are going to be used.

1.2 Transport and packing

The machine comes packed in packing of the following size:

Width = 570 mm, length = 520 mm, height = 410mm

Machine weight plus packing = 20 Kg.

When the machine has been unpacked, check carefully to see if it has suffered any damage during transportation. If you find any problems, please inform the carrier immediately and do not do anything with the machine until the carrier's agent has carried out an inspection.

1.3 Identification label

The ECCO PLUS key cutting machine has an identification label, giving the serial number, the name and address of the manufacturer, the CE mark and the year of manufacture. *See figure 1*

2 Characteristics

of the machine

The ECCO PLUS machine is a robust and precise manual machine for cutting flat cylinder lock keys, vehicle keys, cross-shaped keys and special keys.

2.1 Parts of a key

- 1 Head
- 2 Neck
- 3 Top shoulder
- 4 Bottom shoulder
- 5 Teeth
- 6 Blade
- 7 Back
- 8 Tip

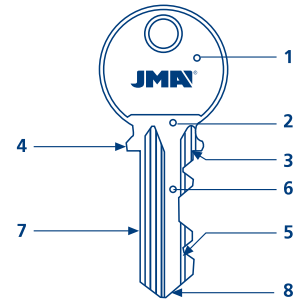

2.2 Main elements of the machine

- 1 Milling cutter
- 2 2-sided clamp
- 3 Clamp handle
- 4 Slide
- 5 Slide handle
- 6 Fold-away stop
- 7 Tracer point
- 8 Start switch
- 9 Tracer point adjustment control
- 10 Plane
- 11 Slide advance lever

See Figure 2

2.3 Technical information

The main technical information is as follows:

Motor: Single phase 220V, 50Hz, 0.18Kw, 1500 rpm, 1.7 Amp.
or Single phase 110V, 60Hz, 0.18Kw, 1800 rpm 3.14 Amp.

Milling cutter: Extra quick speed steel Ø63 x 16 x5 mm.

Speed: 1.500 rpm.

Clamps: 2 sided.

Displacement: On self-lubricated bearings.

Effective travel: X axis = 70 mm.

Dimensions: Width = 530 mm, Depth = 245 mm,
Height = 280 mm.

Weight: 16,5 Kg.

2.4 Components and functional parts

2.4.1 Accessories

See Figure 3

- 1 Size 18 spanner.
- 2 Keys to adjust the height and depth of the teeth.
- 3 Wedges to adjust the tip of the key.
- 4 Recessed wedges to cut cross-shaped keys.
- 5 Set of allen keys (2, 2.5, 3, 4, 5).

2.4.2 Electric circuit

See Figure 4

The main components of the electric circuit and the electronic components are as follows:

- 1 Socket
- 2 Start switch
- 3 Motor
- 4 Microswitch

2.4.3 2-sided clamp

See Figure 5

The clamp is designed to secure a different family of keys on each side. The figure shows the possibilities for cutting on each side of the clamp.

- 1) Cutting the key with support on the back:
 - Keys with normal blade
 - Keys with narrow blade
- 2) Cutting by means of clamping the key by the guide (profile).

3.1 Machine adjustment

3.1.1 Control and adjustment of the side distance

- Place the two adjustment keys (1) in the clamps, so that the head of the adjustment key rests against the inner stop of side 1 or 2 of the clamp.
- Then tighten the clamps.
- Move the clamps with the adjustment keys (1) towards the tracer point (I) and the milling cutter (F), so that the adjustment keys are in the correct position in respect of the tracer point and milling cutter. This is done by moving the slide backwards and keeping it in that position with the help of the handle (M), moving the slide to the right with the help of the arm (B), thereby releasing the slide, and then moving the slide gently over the tracer point (I) and milling cutter (F). See Figure 6
- If the grooves of the adjustment key do not coincide properly with the tracer point and the milling cutter, proceed as follows:
 - By gently loosening the shaft screws (T), you will be able to move the milling cutter to the right or left. You have to move the milling cutter to a position in which it coincides with the groove of the corresponding adjustment key. To carry out this operation, you have to remove the motor guard first.
 - The distance is now perfectly adjusted, with the tracer point and milling cutter coinciding with the respective recesses of the adjustment keys. Now tighten the shaft screws (T).

3.1.2 Control and adjustment of the cutting depth

- Place the two adjustment keys (1) in the clamps, so that the head of the adjustment key rests against the inner stop of side 1 or 2 of the clamp.
- Move the clamps with the adjustment keys (1) towards the tracer point (I) and the milling cutter (F), so that the adjustment keys rest on the tracer point and the milling cutter. The machine slide can be released in the following way: move the slide backwards and keeping it in that position with the help of the lever (M), move the slide to the right, with the help of the arm (B). To lock the slide again, reverse the process, with the slide midway along its travel. Move the slide back with the help of the handle (M) and keeping it in that position, move the slide to the left with the help of the arm (B). With the slide as far to the left as possible, gently release the slide so that it becomes locked.
- Turn the milling cutter by hand. If it gently rubs the adjustment keys, the machine is properly adjusted.
- If the milling cutter turns freely, without rubbing, this indicates that it is too far back in respect of the tracer point and is not cutting deeply enough. On the other hand, if the milling cutter becomes jammed up against the adjustment key, this indicates that it is too far forward in respect of the tracer point and is cutting too deeply.
- If either of these situations should occur, proceed as follows:
 - Undo the screw (L) securing the tracer point (I) and turn the micrometric screw (H). See Figure 7.
 - Move the tracer point forwards or backwards until the milling cutter turns freely and rubs

gently against the adjustment key. Then tighten the tracer point screw (L). The machine is now in perfect working order.

3.2 Key cutting operation

- Insert the original key into the left-hand clamp, keeping it a distance of 2 to 3 mm from the edge of the clamp. *See Figure 8.*
- Tighten up the clamp, keeping the back of the key properly pressed against the base of the clamp.
- Insert the key blank to be cut into the right-hand clamp and, before tightening up the clamp, raise the gauge (C) and align the two keys. Ensure that the two pointers of the gauge are resting firmly up against the top shoulders of both keys. Finally, tighten up the clamps.
- Both the original key and the key blank to be cut should be inserted in the left-hand side of the respective clamps.
- Withdraw the gauge (C). Start the machine and release the slide (as explained in point 3.1.2). Move the keys towards the tracer point (I) and the milling cutter (F).
- Remember that you have to work from left to right. Rest the original key against the tracer point and start to work, moving the slide from right to left, using the arm (B), ensuring that the pressure exercised on the tracer point is that required by the spring that acts on the slide shaft.
- Once the key has been cut, return the slide to its initial position, as explained in chapter 3.1.2. Then remove the keys by undoing the clamps.
- If the key cutting operation has left any burrs on the cut key, these can be removed with the plane that the machine has been fitted with for this purpose.

3.2.1 Duplication of narrow bit key. Use of rods 1.2 and 1.7

The rods are inserted between the bottom of the clamp and the back of the key when the key to be duplicated has a narrow bit. The rods prevent contact with the clamp itself by making the key protrude further. *See Figure 9.*

3.2.2 Cutting keys without shoulders

Insert the two wedges (2) (*see Figure 10*) into the vertical slots (R) of each clamp, depending on the length of the key to be cut. Rest the tips of the keys against the wedges (2). The keys are now adjusted. Then tighten up the clamps. Before starting to cut the key, it is advisable to remove the wedges.

3.2.3 Cutting cross-shaped keys. Side 1 of the clamp

This type of key must be inserted into the clamps from left to right. Place the wedges (5) (*see Figure 11*) with the opening or recess facing upwards, in one slot or the other (R), depending on the length of the key to be cut. The teeth of the key can be cut in three operations, by turning and locking the shoulder of the key against the wedge (5) each time.

4 Maintenance and safety

When carrying out maintenance operations, the following requirements must be met:

- 1 Never carry out any maintenance operation with the machine switched on.
- 2 Unplug the machine.
- 3 The indications in this manual must be strictly adhered to.
- 4 Use original spare parts.

4.1 Changing the milling cutter

Undo the two milling cutter guard screws and remove the guard.

To change the milling cutter: With the help of the two size 18 spanners, lock the milling cutter shaft and undo the nut (K) – left-hand thread – securing the milling cutter (F). Then replace the milling cutter and finally put the milling cutter guard back into place. *See Figure 12.*

To change the plane: Lock the milling cutter shaft with the help of a size 18 spanner. Undo the screw (R) with the help of an allen key. Replace the plane and finally put the milling cutter guard back into place.

4.2 Safety recommendations

- 1 Do not try and start or handle the machine until all safety matters, installation instructions, operator guides and maintenance procedures have been fulfilled and understood.
- 2 Always switch off the power supply before carrying out any cleaning or maintenance operation.
- 3 Always keep the machine as well as its surroundings clean.
- 4 Work with dry hands.
- 5 Use safety glasses, even if the machine is fitted with guards.
- 6 Ensure that the machine is earthed.



Figura 1 / Figure 1 / Abbildung 1



Figura 2 / Figure 2 / Abbildung 2



Figura 3 / Figure 3 / Abbildung 3



Figura 4 / Figure 4 / Abbildung 4

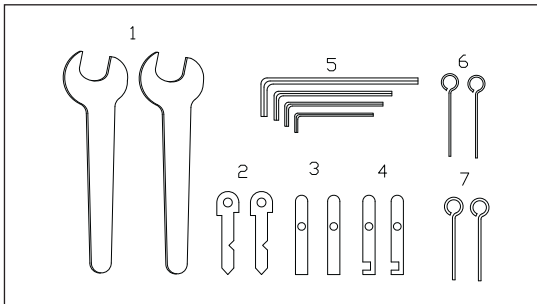

Figura 5 / Figure 5 / Abbildung 5

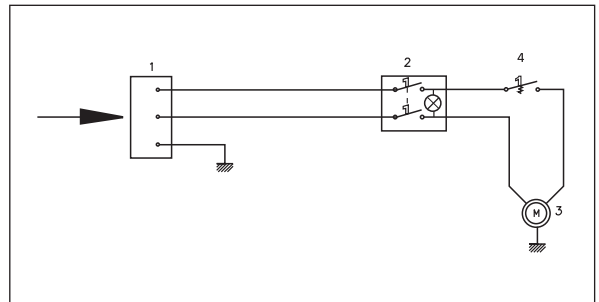

Figura 6 / Figure 6 / Abbildung 6

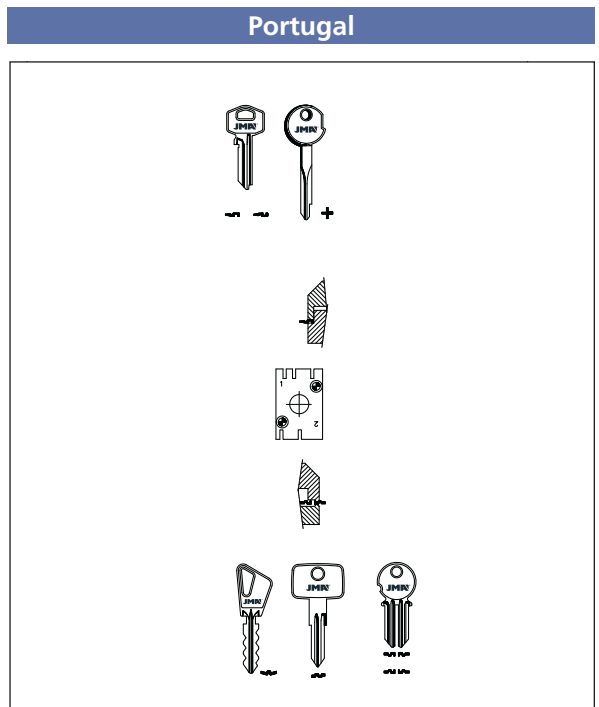
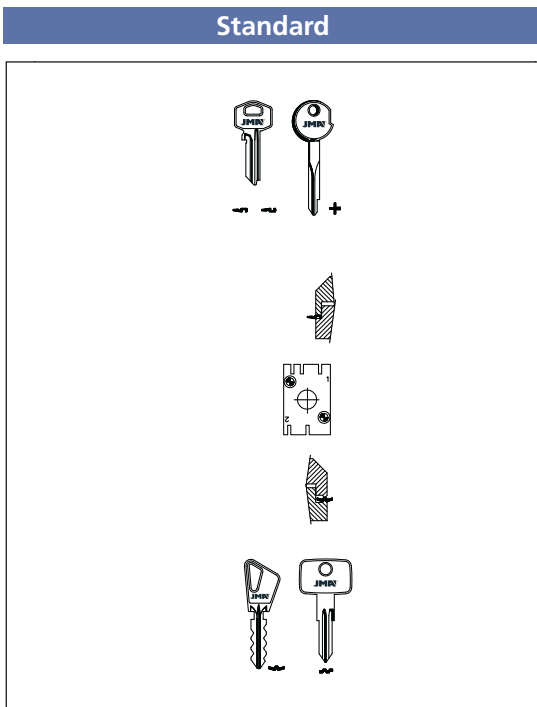

Figura 7 / Figure 7 / Abbildung 7

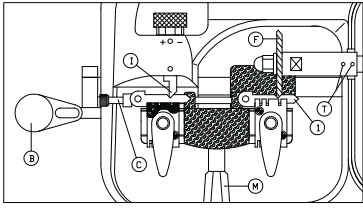

Figura 8 / Figure 8 / Abbildung 8

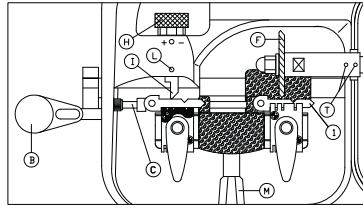

Figura 9 / Figure 9 / Abbildung 9

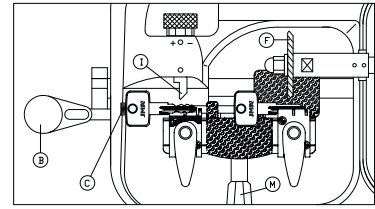

Figura 10 / Figure 10 / Abbildung 10

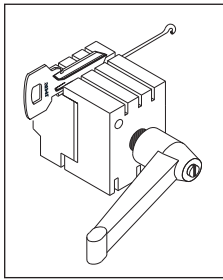

Figura 11 / Figure 11 / Abbildung 11

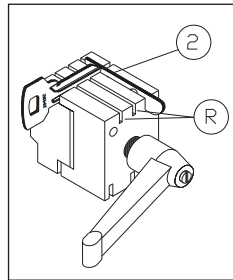

Figura 12 / Figure 12 / Abbildung 12

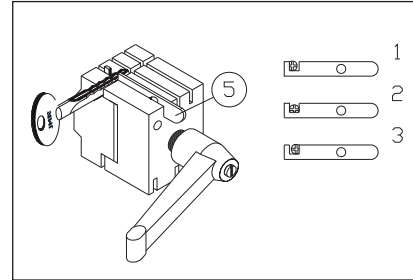

ECCO PLUS
2005

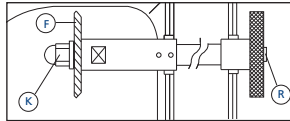
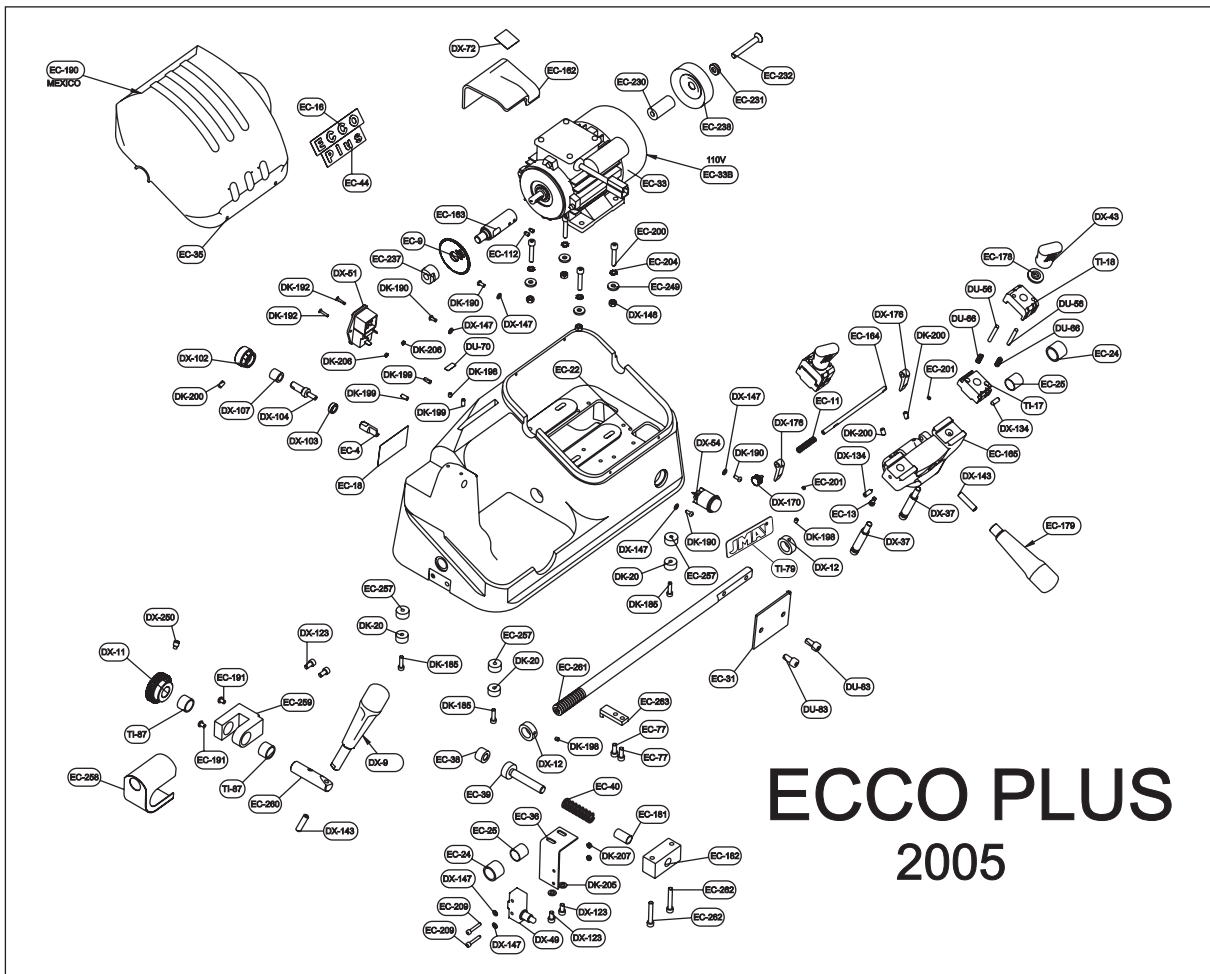

Bidekurtzeta, 6. Apdo. 70
20500 Arrasate-Mondragón
(Gipuzkoa) ESPAÑA
Tel. + 34 943 79 30 00 / 943 79 33 32
Fax. + 34 943 79 72 43
www.jma.es
e-mail:jma@jma.es